

THE START OF A NEW ERA IN THE KITCHEN

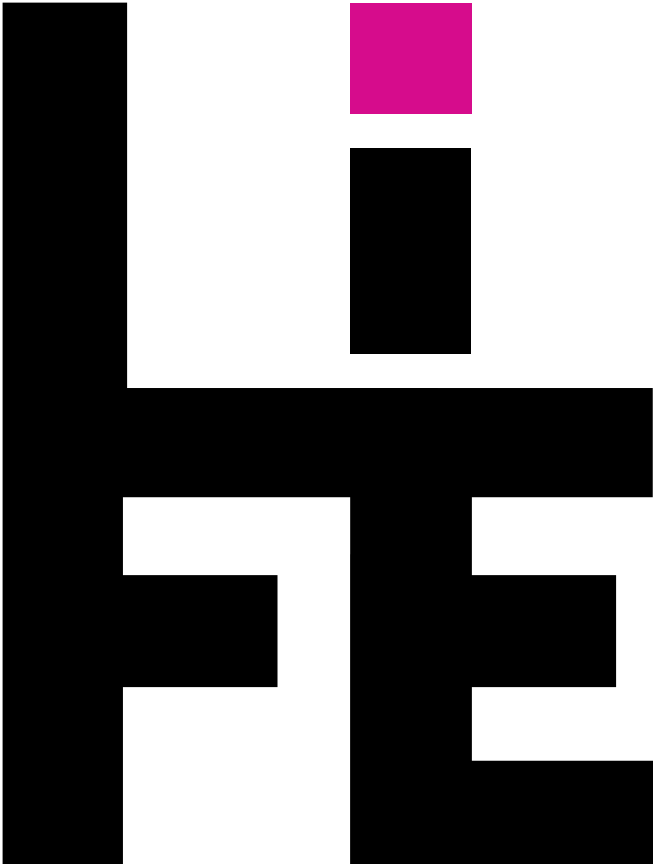



Patented

COLDLINE

Coldline works daily alongside top food and pastry chefs in the most prestigious restaurants around the world, providing the most advanced blast chilling, storage and proving solutions.

LIFE, THE START OF A NEW ERA IN THE KITCHEN

The refrigerator was introduced into our homes during the last century and since then this tool has become an essential feature of the modern household. Today, the LIFE multifunction blast chiller is opening up a new era for the kitchen.

Now you can enjoy the benefits of intense cold or gentle heat in your own kitchen and achieve amazing results just like professional chefs.





FOOD IS LIFE

Back in our grandmothers' day, the range of food you could eat was very limited. Nowadays, however, there are thousands of products on supermarket shelves that bear only the merest resemblance to the food our ancestors ate.

There is widespread use of chemicals, sugar and additives in the food industry so we have to ask, what impact are they having on our health? It has been demonstrated that food and wellbeing are closely linked.

With LIFE, you finally get the chance to say no to massproduced products and instead use fresh, natural ingredients and keep them fresh for longer.

Cooking at home will be quick and easy: you can prepare the kind of healthy, wholesome dishes our grandmothers used to make.

LIFE, TECHNOLOGY THAT'S A STEP AHEAD

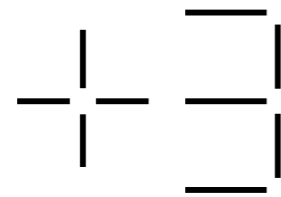

Blast chilling

Quickly cools raw or freshly cooked food to +3°C, stops bacterial growth, increases fridge life by 70%, maintaining quality intact.

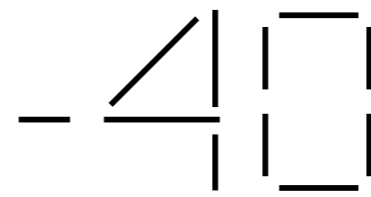

Blast freezing

Quickly cools raw or freshly cooked food down to temperatures as low as -40°C while preserving their original quality. Increases freezer storage times to as much as several months.

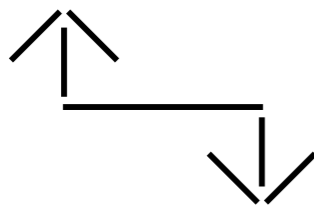

Storage

Keeps food at the desired temperature in the -40°C to + 45°C range with fan speeds that can be adjusted from 25% to 100%.

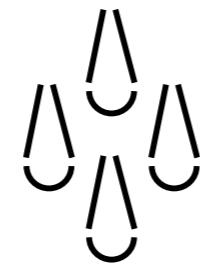

Thawing

Thaw food quickly and entirely safely, while keeping all the original quality without any risk to your health.

8 FUNCTIONS, INFINITE POSSIBILITIES



Proving

Creates the ideal microclimate for perfect proving, encouraging the optimal development of air pockets inside the dough as well as boosting flavour and fragrance. The cycle can be run immediately or programmed with a timer.



Bottle chilling

Quickly chills your wine, beer and beverages to the desired temperature.

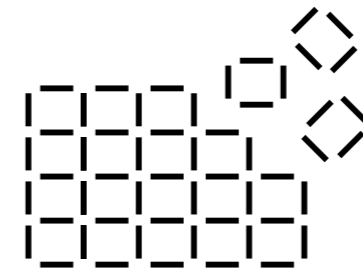

Chocolate

Lets you make chocolates of all shapes and sizes using the dedicated crystallization and "pop-out" cycles.

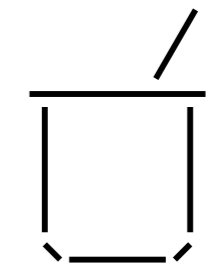

Yoghurt

Lets you make creamy natural yoghurt using just good-quality milk.

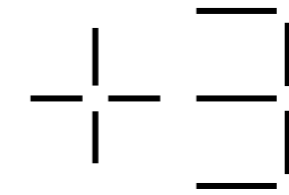

BLAST CHILLING

Do you know why food goes off quickly?

Bacteria transform the chemicals found in food, causing them to deteriorate, while the +65°C to +10°C temperature range provides ideal conditions for bacteria to thrive.

This is exactly what happens in the kitchen when we leave a cooked product to cool at room temperature.

Blast chilling freshly cooked food to +3°C extends its fridge life considerably, by as much as 70%, maintaining its original quality intact.

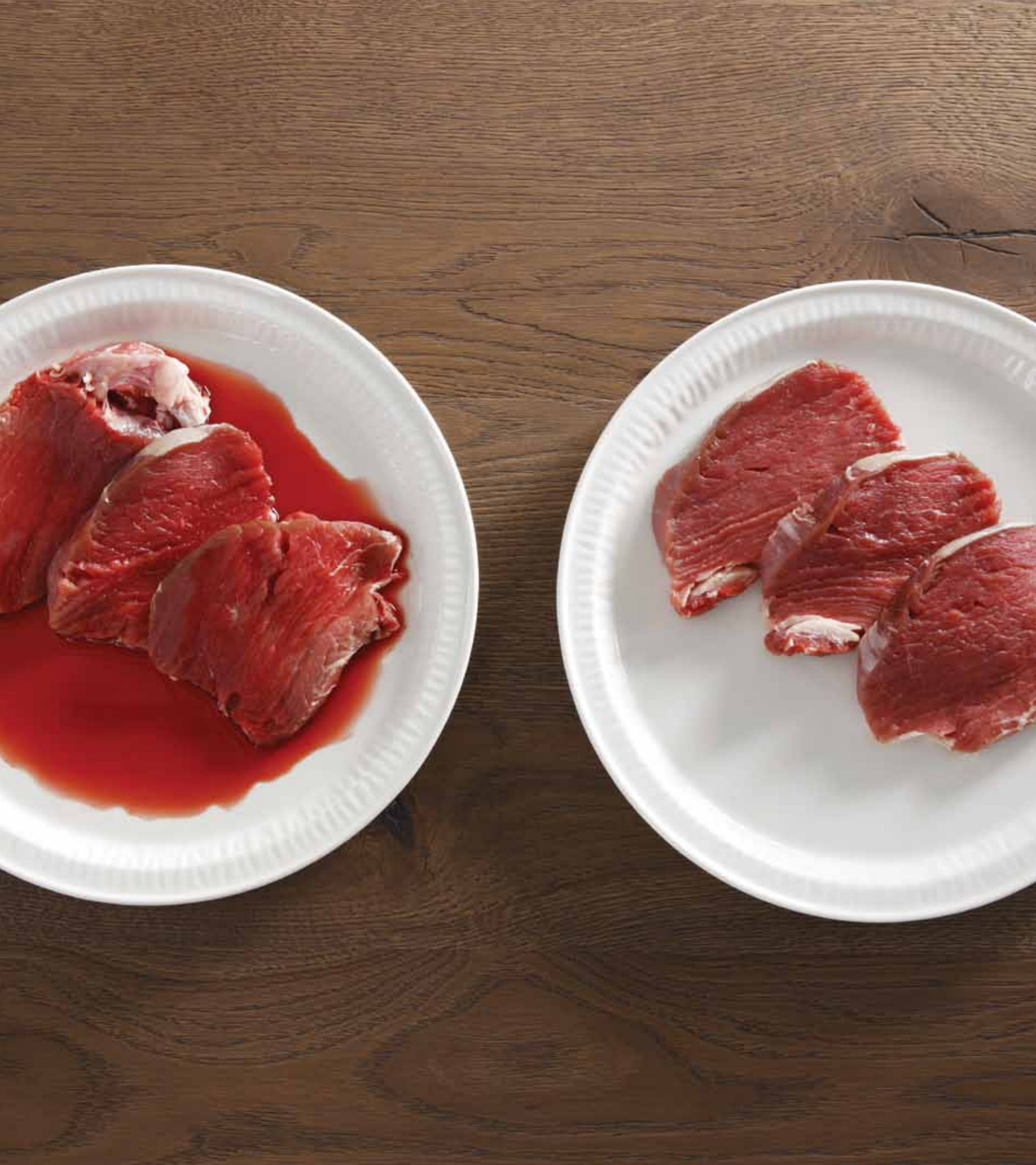

-40

BLAST FREEZING

Are freezing and blast freezing synonyms? Absolutely not! There is a key variable involved in freezing and blast freezing processes that makes the two techniques profoundly different: time. Unlike freezing, blast freezing is a very fast process that, by exploiting temperatures as low as -40°C , allows the food's organoleptic qualities - its flavour, fragrance and appearance to survive the process intact.

Have you ever tried snapping a piece of frozen meat? It will bend but there's no chance of it actually breaking. Try again after a blast freezing cycle with LIFE and you'll hear a sharp, precise crack as this process leads to the formation of microcrystals.

Water freezes without tearing the cells: whether it's meat, fish, fruit or vegetables, there's no change to the food's biological structure.

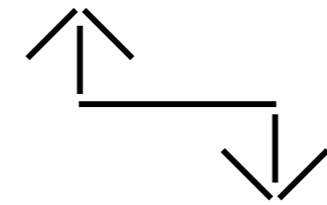

STORAGE

LIFE technology is unique: it allows you to adjust temperature from -40°C to $+45^{\circ}\text{C}$ with a fan speed adjustable from 25% to 100%; what other device gives you so much flexibility? Have you got guests over for dinner and you've run out of fridge space? Use LIFE to store frozen desserts or ice cream, and you'll have them ready to eat at the ideal temperature to your guests' astonishment and delight.



PROVING

Is there anything better than home-made bread? No matter what shape or colour it comes in, fresh, fragrant bread is always a hit at lunch or dinner. But for perfect proving, the dough has to be kept at the right temperature for just the right length of time, without sudden changes in humidity levels. A condition that you can't recreate at home, but you can achieve with LIFE! You'll get a supreme quality dough that's ready to pop in the oven when you want.

LIFE gives you a professional feature that actually allows you to slow down the action of the yeast and program the rising process to the exact time you plan to start baking. You can also take advantage of the feature to prove overnight: by lengthening process times, you can reduce the amount of yeast used and get light, highly digestible bread, focaccia flat bread and pizzas.

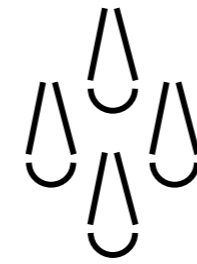

THAWING

Thawing raw fish and meat has to be one of the slowest, most delicate tasks you'll ever tackle in the kitchen.

Using running water is not recommended, while microwaves although speeding up the process - cook the food partially and affect the protein part: quality is inevitably compromised as a result.

Thawing in the fridge is effective, but comes with waiting times that are just too long for our busy daily lives.

Using technology borrowed from the professional world, LIFE makes the thawing process amazingly quick and safe, so you won't be able to tell the thawed product from a fresh one!

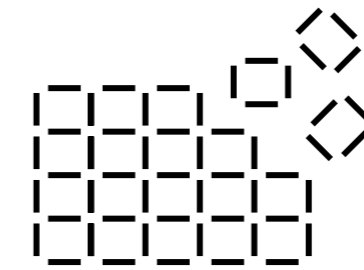

CHOCOLATE

Bitter, bittersweet or sweet chocolate, a wonderful mixture made by mixing together cocoa mass, cocoa butter and sugar. Simply allowing the melted chocolate to cool won't give you a glossy, crunchy product as the cocoa butter doesn't crystallize properly. A normal fridge can't provide the right temperature and results in a poorer quality product.

With LIFE, you can run a "pop-out" cycle to stabilize the chocolate and promote optimal flavour development.

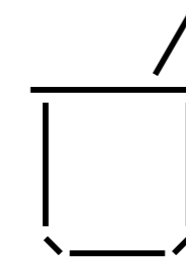

YOGHURT

Yoghurt is a light, nutritious food that improves our wellbeing and can even be eaten by mildly lactose-intolerant people. LIFE recreates the ideal environment for bacteria to turn milk into yoghurt.

You can choose the best milk, prepare small or large batches and add your preferred fresh fruit for a healthy, nutritious snack you can grab out of the fridge any time.

At last, you can get rid of all those massproduced products clogging your pantry with their added sugar, preservatives and flavours.

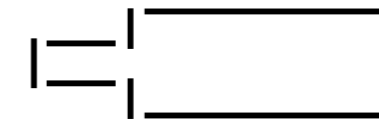

BOTTLE CHILLING

It happens all the time: you've got a great bottle of wine but when you go to drink it, it's at the wrong temperature - what a waste! With the bottle chill function, all you have to do is set the serving temperature you want, wait a few minutes and, hey presto, you're ready to raise a glass with friends. You can also use LIFE to chill water, beer and your favourite beverages.







GET BACK INTO THE KITCHEN WITH LIFE

Recipes at your finger tips

Blast chill, blast freeze, store, prove and defrost with technology that manages temperature and fan speed dynamically. Simply touch the display and enter the wonderful world of LIFE.

Soups	Sauces	Pasta
Rice	Meat	Fish
Fruits Vegetables	Pizza	Desserts



MEAT

Mixed grill in 8 minutes

Meat that has been blast frozen with LIFE can be cooked without having to be defrosted first.

A chicken breast, a slice of beef and a kebab can be cooked on a pre-heated hot plate in just 8 minutes! A mixed grill ready to serve in a flash with results of the highest quality.

Excellent roasts with LIFE

Cook a veal roast in the oven with carrots, celery and onion. As soon as you take it out, blast chill to +3°C using the core temperature probe. The evaporation process stops immediately so that none of the juices are lost: the meat stays tender, flavoursome and nutritious. You can carve it without it falling to bits, eat part of it straight away and leave the rest in the fridge for up to a week.

Have you ever considered blast freezing cold cuts?

By blast freezing with LIFE to -40°C, cold cuts will have the same bright colour and yummy flavour as freshly sliced meat. You can buy fresh cold cuts of a guaranteed quality from the best delicatessens and keep a supply ready for use when you need them. Salami, prosciutto, cooked ham, speck, bresaola...they can all be defrosted at room temperature in a matter of seconds, keeping all their original properties.



FISH

Risk-free sushi

Raw fish is gaining ground as a family staple.

However, there are risks associated with contamination by Anisakis, a parasite that is hazardous to health and can only be eliminated with lengthy cooking or low temperatures.

When blast frozen and stored at -20°C for at least 24 hours, the fish no longer poses a hazard.

Fish blast frozen with LIFE

Many people think that blast frozen fish loses some of its quality. Nothing could be further from the truth.

With the blast freeze function taking the temperature down to -40°C , the water contained in the flesh solidifies quickly without tearing the fibres. When blast frozen and defrosted with LIFE, shellfish, molluscs and fish fillets will be of a much higher quality than their fresh counterparts that have been kept in the fridge for 1 day.

How do you defrost fish?

Use LIFE to defrost fish you want to serve raw and you'll get amazing results. The product stays moist, without oxidizing or losing any of its colour or texture.

Both structure and flavour will be just like in the original fish and it will be impossible to tell the defrosted and fresh fish apart. There's just one difference between freshly caught fish and fish defrosted with LIFE: the latter doesn't pose a potential health hazard!

VEGETABLES

Can you grill blast frozen vegetables?

Water-rich vegetables are damaged in a traditional freezer, their flavour and texture are altered and nutrients are lost. With LIFE, you can blast freeze your favourite pre-cut vegetables and, when the time comes, all you have to do is arrange them on a pre-heated hot plate and voilà: a tasty side dish in a matter of minutes.

Garden-fresh minestrone

Pick ripe vegetables from your garden, wash, chop and blast freeze with LIFE and they can be kept in the freezer for a long time. You can prepare excellent minestrone and fantastic soups, adding the odd crouton and a drizzle of extra virgin olive oil: the dish will be ready in the blink of an eye! Say goodbye to mass-produced products and instead enjoy the natural flavour of fresh vegetables no matter what the season.

Baby food

Fruit and vegetables are a must in any baby's or toddler's diet as soon as they start on solid foods. Fresh, nutritious, wholesome products are certainly the best choice, but our time-poor lives mean we often end up resorting to mass-produced homogenized food. LIFE is here to help! Prepare single portions, blast chill to +3° and keep them in the fridge. Grandparents and babysitters will be delighted to find everything already prepared. Alternatively, blast freeze fruit and vegetables with LIFE: you will have a ready supply of top-quality food for months to come, a healthy, 100% natural product just the way you like it.





FRUIT

Ready supply of seasonal produce

The blast freezing technique perfected with LIFE allows you to blast freeze fruit, avoiding darkening, freezer burn or frost formation on their surface. Blast freezing gives you a ready supply of fruit for making such excellent dishes as fruit salads, tarts, strudels, cakes and decorations.

Fruit sorbet at -40°C

An original take on the classic sorbet is fruit served directly at -40°C! Thinly slice the fruit - you can use oranges, apples, strawberries, berries or anything else you like - place it on a baking tray lined with baking paper and blast freeze with LIFE. As simple as that! A natural sorbet ready for you to astound your guests with.



PASTA

A delicious starter in three minutes

Blast chilling pasta produces a thermal shock that stops the cooking process instantly. The pasta doesn't stick together because LIFE gelatinizes the starch and you don't even have to add oil. Cook the pasta 'al dente' when you have time and keep it in the fridge for up to 3 days.

When you get in from work, you can simply toss it directly in a frying pan with your favourite sauce, knocking up a healthy, tasty, appetizing dish in a matter of minutes.

Gnocchi: blast chilled or blast frozen?

How would you like to have a supply of home-made gnocchi ready to eat at a moment's notice? Prepare a generous amount of these potato treats, cook them and blast chill to +3°C for a week's worth of food. Alternatively, blast freeze to -40°C while raw and create a supply you can get out and prepare whenever you're in the mood. You can cook the product direct from frozen for results that never fail to live up to your expectations. You can blast freeze all manner of fresh pasta with LIFE, from tagliatelle to cannelloni.

Nutritious soups

There's no shortage of ready-made soups of every kind at the supermarket, but they all come with a generous helping of additives and preservatives. Fresh or dried vegetables are healthier and superior in quality but require lengthy preparation. LIFE saves you so much time! The trick is to prepare a large batch and divide it up into single portions you can then blast freeze to -40°C. In a matter of minutes, you have tasty, healthy, nutritious food ready to serve.



YEAST-RAISED PRODUCTS

Start your day in the best possible way

We are bombarded with adverts promoting attractive products in colourful packaging that are touted as the ideal breakfast food, but just how good are they for us really?

With LIFE, you can make brioches, croissants, danish pastries and yoghurt cakes and allow them to prove naturally with amazing results! Can you imagine a better breakfast?

Flour, water, yeast and a pinch of salt

Good bread is the kind you make at home with flour, water, yeast and a pinch of salt. None of us, though, would think of making bread every day. Prepare more dough than you would for a single batch, shape it into individual rolls, bake them and blast freeze your supply of bread with LIFE.

You can defrost the bread as you need it, enjoying all the fragrance of the freshly baked product each time.

Compare the cost of the individual ingredients with the price of bread you'd expect to pay at the bakery and you'll see an immediate difference!

The secret to fabulous pizza

Slow fermentation lets you reduce the amount of yeast, but it needs to be controlled at constant, accurate temperatures.

With LIFE, you can prove the dough with cycles running for as long as 24 hours, even at a low temperature.

If you use sourdough, the dough will be rich in compounds that also add to the pizza's flavour and fragrance.

The result is a light, soft and highly digestible pizza.

CAKES AND PASTRIES

Sponge cake

If cooled at room temperature, sponge cake loses a lot of moisture, turning out dry and not very appetizing. Blast chilling to $+3^{\circ}\text{C}$, on the other hand, stops evaporation while the product is still warm and results in a soft, light sponge that keeps its superior properties for a long time.

Layered mousse without the waiting time

Mousse makes a delicious dessert, but it takes a long time to prepare, especially if you're layering it. You can't add a layer until the one before has cooled sufficiently. With LIFE, you can cool each layer straight away, while a low fan setting won't cause the mousse to deflate or ruffle its surface. If you prepare a few extra portions, you can always blast freeze them and be assured of an excellent ready-to-serve dessert whenever you decide to get them out.

Risk-free creams and custards

Prepare the cream, blast chill to $+3^{\circ}\text{C}$ and in just a few minutes the cream is ready for filling puffs or cakes.

By blast chilling egg creams, you're protecting them from attack by bacteria and extending their fridge life.

All you need to make crème caramel is milk, cream and brown sugar. Blast freeze single portions with LIFE and you can keep them in the freezer at home with complete peace of mind. So when you feel like a snack or a treat, you can have a delicious, nutritious dessert ready in a matter of minutes.





YOGHURT

Yoghurt breeds more yoghurt

With LIFE, making yoghurt is easy and fun.

You'll need: full-fat yoghurt or a pack of starter culture, full-cream milk and a few glass jars. Pour the milk into the jars, add a small amount of yoghurt or starter culture and run the program.

You can add coffee, chocolate flakes, fresh fruit, honey, jam or cereals. Once the cycle has finished, put the lids on the jars and they will keep for up to 10 days in the fridge, so you can enjoy all their healthy goodness for breakfast or as a snack.



ICE CREAM AND ICE LOLLIES

100% natural ice cream

Children fill their warm summer afternoons with play and always look forward to an afternoon snack: what better than an ice cream to satisfy their cravings? Get some really fresh fruit - like strawberries or raspberries - and freeze to -40°C with LIFE. Tip into the blender, add an egg white and 1 tablespoon of sugar and blend for a few minutes.

You'll get a fantastic ice cream that kids will go crazy for it.

Finger-licking good

There's no denying that the ice creams you buy in the shops are yummy, but with all that sugar and fat, they can come in at 500 calories a pop! Home-made ice cream, on the other hand, is wholesome because it's free of artificial preservatives, colours and flavours. Making ice cream is simple and fun, especially if you get the kids involved.

You can use the special moulds to produce ice lollies in cheerful, imaginative shapes. You might even want to dip them in dark chocolate and crushed hazelnuts.

CHOCOLATE

Home-made chocolates

Here's a brilliant Christmas gift idea for family and friends! Choose the chocolate - white, milk or dark - melt it over a bain-marie and pour into moulds in whatever shape you prefer. Run a crystallization cycle with LIFE and in ten minutes you'll have chocolates worthy of a master chocolatier!



PROFESSIONAL TECHNOLOGY IN YOUR HOME

W60 W45 W30

The refined, elegant design of the built-in versions blend in perfectly with the style of a modern kitchen, while the freestanding model can sit directly on the worktop, wherever is most convenient.





Designed for improved comfort

The AISI 304 stainless steel interior, the door without handle and the innovative touch screen display give LIFE an elegant, harmonious look.



Aviation technology

Insulation produced with materials borrowed from the aviation industry ensures unbeatable energy savings and makes LIFE comfortable to use and quiet to run.



Patented solutions

The innovative air flow system increases the performance efficiency of the blast chiller and reduces the noise level.



Controlled fan speed

LIFE has an extraordinary feature: it allows cooling to be "finetuned", increasing or reducing fan speed based on the type of product.



Even temperature distribution

The position of the ventilation system at the back to the device ensure that a constant temperature is maintained in all part of the blast chiller.



High output and low consumption

LIFE adjusts power constantly so that energy is not wasted unnecessarily. The compressor stops during stages when no additional cooling power is needed.



Information on demand

Forget the old user manual. When you hold down a key for 3 seconds, it gives you clear, precise information on the function selected.



Core temperature probe

The core temperature probe is a device that tells you the temperature in the middle of the product, thus optimizing work cycles and reducing energy consumption.



Water drain plus

The condensed water collects and flow out to the drain at the bottom of the blast chiller. If the blast chiller isn't connected to the drainage system the hole can be blocked.



Interior lighting

Lighting is designed to provide excellent visibility inside. LED technology ensures low consumption and doesn't affect the fridge's interior temperature.



USB connection

LIFE can always be uploaded with the latest software which includes new recipes by using the USB port.



Gas R290

LIFE uses R290 gas, which delivers 30% higher cooling efficiency than traditional gases as well as a low environmental impact with a GWP of just 3.8.

LIFE W60 BUILT-IN



BLACK ELEGANCE
cod. W60N-CL



WHITE ICE
cod. W60B-CL



INOX PROFESSIONAL
cod. W60A-CL



BLACK ELEGANCE INOX
cod. W60NX-CL



WHITE ICE INOX
cod. W60BX-CL

Functions

Blast chilling, blast freezing, proving, thawing, storage, chocolate, yoghurt, bottle chilling

Operating modes

Recipes, core probe, without core probe

Standard fittings

3 racks 448 x 325 x 32 mm, core probe, sanitizer

Temperatures

-40°C / +45°C

Fan speed

Adjustable from 25% - 100%

Display

Touch screen, 4.3 inches

Capacity

45 litres, 4 trays

Weight

60 kg

Refrigerant gas

R 290, GWP 3,3

Interior measurements

455 x 349,5 x 308 mm

Exterior measurements

595 x 575 x 603 mm

Packaging measurements

620 x 680 x 718 mm

Cooling capacity

900W
[Evap - 10°C cond. +40°C]

Power supply

220V-240V / 50Hz

Maximum power demand

540 W - 2.8A

Exterior finish

Glass, Scotch Brite

Interior finish

AISI 304 stainless steel
scratch-resistant

Door hinge

Bottom, lift-up door

LIFE W45 BUILT-IN



BLACK ELEGANCE
cod. W45N-CL



WHITE ICE
cod. W45B-CL



INOX PROFESSIONAL
cod. W45A-CL



BLACK ELEGANCE INOX
cod. W45NX-CL



WHITE ICE INOX
cod. W45BX-CL

Functions

Blast chilling, blast freezing, proving, thawing, storage, chocolate, yoghurt, bottle chilling

Operating modes

Recipes, core probe, without core probe

Standard fittings

2 racks 448 x 325 x 32 mm, core probe, sanitizer

Temperatures

-40°C / +45°C

Fan speed

Adjustable from 25% - 100%

Display

Touch screen, 4.3 inches

Capacity

26 litres, 3 trays

Weight

55 kg

Refrigerant gas

R 290, GWP 3,3

Interior measurements

455 x 349,5 x 178 mm

Exterior measurements

595 x 575 x 462 mm

Packaging measurements

620 x 680 x 590 mm

Cooling capacity

900W
[Evap - 10°C cond. +40°C]

Power supply

220V-240V / 50Hz

Maximum power demand

540 W - 2.8A

Exterior finish

Glass, Scotch Brite

Interior finish

AISI 304 stainless steel
scratch-resistant

Door hinge

Bottom, lift-up door

LIFE W30



BLACK ELEGANCE INOX
cod. W30N

Functions

Blast chilling, blast freezing, proving, thawing, storage, chocolate, yoghurt, bottle chilling

Operating modes

Recipes, core probe, without core probe

Standard fittings

1 racks 322 x 260 mm,
1 stainless steel tray GN1/2
core probe, sanitizer

Temperatures

-30°C / +45°C

Fan speed

Adjustable from 25% - 100%

Display

Touch screen, 4.3 inches

Capacity

22 litres, 3 trays

Weight

40 kg

Refrigerant gas

R 290, GWP 3,3

Interior measurements

329 x 300 x 252-211 mm

Exterior measurements

558 x 381 x 359 mm

Packaging measurements

645 x 475 x 458 mm

Cooling capacity

900 W
[Evap - 10°C cond. +40°C]

Power supply

220V-240V / 50Hz

Maximum power demand

540 W - 2.8A

Exterior finish

Glass, Scotch Brite

Interior finish

AISI 304 stainless steel
scratch-resistant linen

Door hinge

Bottom, lift-up door

OPTIONAL

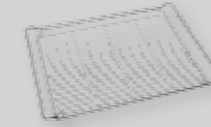

Rack stainless steel 60/45

code: O223320447
model: W60 - W45
size: 447 x 320 mm

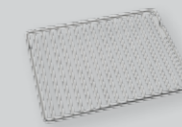

Rack stainless steel 30

code: O223260322
model: W30
size: 322 x 260 mm



Wooden box, black laminate

code: O330200010
model: W60
size: 600 x 588 x 628 mm



Stainless steel tray GN1/2

code: O273325265
model: W60 - W45 - W30
size: 325 x 265 x 40 mm



Stainless steel tray GN1/3

code: O273325175
model: W60 - W45 - W30
size: 325 x 175 x 40 mm



Stainless steel tray GN1/4

code: O273265162
model: W60 - W45 - W30
size: 265 x 162 x 40 mm

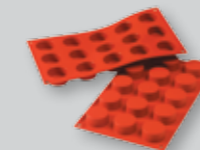

Silicone mould 01

code: O331301810
model: W60 - W45 - W30
size: 15 x 30 ml - 300 x 175 x 25 mm

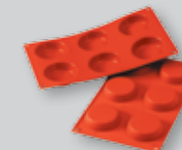

Silicone mould 02

code: O331301820
model: W60 - W45 - W30
size: 6 x 52 ml - 300 x 175 x 25 mm

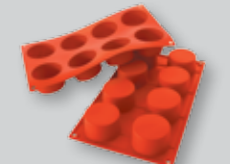

Silicone mould 03

code: O331301830
model: W60 - W45 - W30
size: 8 x 90 ml - 300 x 175 x 25 mm

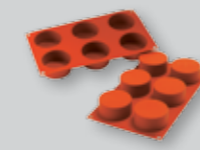

Silicone mould 04

code: O331301840
model: W60 - W45 - W30
size: 6 x 133 ml - 300 x 175 x 25 mm



Classic ice cream mould + 50 wooden sticks

code: O331201110
model: W60 - W45 - W30
size: 200 x 113 x 20 mm



Heart ice cream mould + 50 wooden sticks

code: O331201120
model: W60 - W45 - W30
size: 200 x 113 x 20 mm



Cream caramel mould

code: O331080510
model: W60 - W45 - W30
size: 2 pz, 78 x 48 - 160 ml

Sanitizer

code: O330100010
model: W60 - W45 - W30
size: 75 ml



Other accessories are available on
the website coldlineliving.com

INSTALLATION

W60

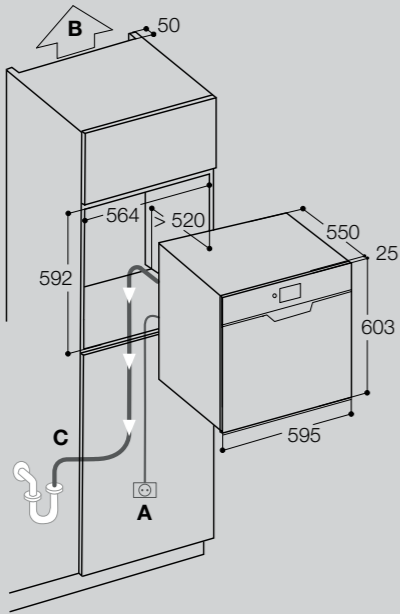

W45

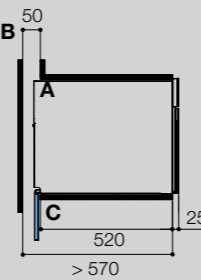
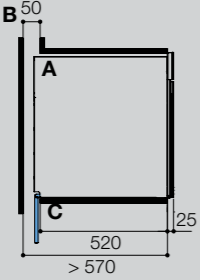
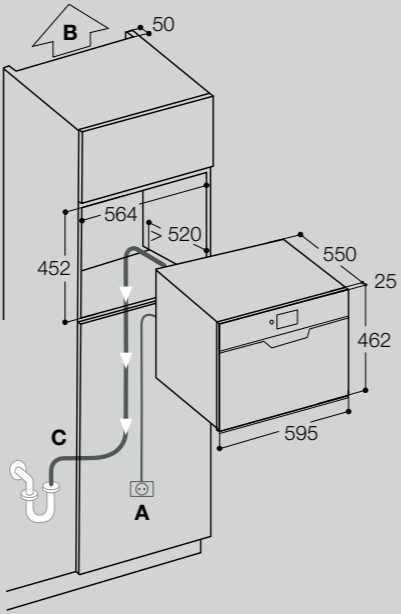

W30

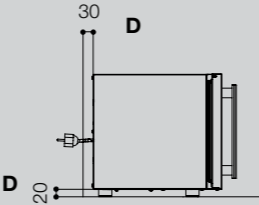
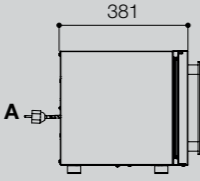
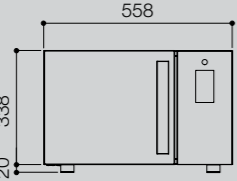

- A:** 3.40 m electrical cable with Schuko plug.
- B:** To recirculate air, you will need free space measuring at least 50 mm in the upper part of the cavity for housing the unit.
- C:** It is advised that LIFE blast chiller is plumbed into the drainage system.
To order the blast chiller version without drainage add the letters -DF at the end of the product code (ex: W60N-CL-DF).
- D:** To allow air to circulate, you must allow at least a 30 mm clearance behind the appliance and 20 mm in the bottom part.



coldlineliving.com

Coldline Srl

Via Enrico Mattei, 38
35038 Torreglia - Padova - Italy
Tel. +39 049.9903830
www.coldlineliving.com
info@coldlineliving.it